

**TECHNICAL MANUAL
OPERATOR'S, UNIT AND
DIRECT SUPPORT MAINTENANCE MANUAL
(INCLUDING REPAIR PARTS AND SPECIAL TOOLS LIST)
FOR
PRECISION UNIVERSAL PENETROMETER
MODEL TS-73510 AN-2
NSN 6635-00-359-2232**

This technical manual is an authentication of the manufacturer's commercial literature and does not conform with the format and the content requirements normally associated with Army technical manuals. This technical manual does, however, contain all essential information required to operate and maintain the equipment.

Approved for public release; distribution is unlimited.

**HEADQUARTERS, DEPARTMENT OF THE ARMY
28 SEPTEMBER 1990**

This technical manual is an authentication of the manufacturer's commercial literature and does not conform with the format and the content requirements normally associated with Army technical manuals. This technical manual does, however, contain all essential information required to operate and maintain the equipment.

Approved for public release; distribution is unlimited.

SUPPLEMENTARY INTRODUCTORY MATERIAL

1-1. Maintenance Forms and Records.

Department of the Army forms and procedures used for equipment maintenance will be those described by DA Pam 738-750, The Army Maintenance Management System.

1-2. Reporting Errors and Recommending Improvements.

You can help improve this manual. If you find any mistakes or if you know of a way to improve the procedures, please let us know. Mail your letters, DA Form 2028 (Recommended Changes to Publications and Blank Forms), or DA Form 2028-2 located in the back of this manual, directly to: Commander, U.S. Army Troop Support Command, ATTN: AMSTR-MCTS, 4300 Goodfellow Blvd., St. Louis, MO 63120-1798. A reply will be furnished to you.

1-3. Destruction of Army Material to Prevent Enemy Use.

Refer to TM 750-244-3 for instructions covering the destruction of Army Material to prevent enemy use.

1-4. Administrative Storage of Equipment.

a. Placement of equipment in administrative storage should be for short periods of time when a shortage of maintenance effort exists. Items should be in mission readiness within 24 hours or within the time factors as determined by the directing authority. During the storage period appropriate maintenance records will be kept.

b. Before placing equipment in administrative storage, current preventive maintenance checks and services should be completed. Shortcomings and deficiencies should be corrected, and all modification work orders (MWO's) should be applied.

c. Storage site selection. Inside storage is preferred for items selected for administrative storage. If inside storage is not available, trucks, vans, conex containers and other containers may be used.

Precision[®]

Instruction Manual TS-73510 AN-2



**Universal Penetrometer
Catalog 73510**

Precision Scientific

Precision Scientific Inc. 3737 W. Cortland St. ■ Chicago, IL 60647 ■ 312-227-2660 Telex: 4330120 (ITT), 254028 (WU) ■ Fax: 312-227-1828

Universal Penetrometer**Catalog 73510****Introduction**

Your satisfaction and safety are important to PRECISION SCIENTIFIC and a complete understanding of this unit is necessary to attain these objectives.

As the ultimate user of this apparatus, it is your responsibility to understand its proper function and operational characteristics. This instruction manual should be thoroughly read and all operators given adequate training before attempting to place this unit in service. Awareness of the stated cautions and warnings, and compliance with recommended operating parameters-together with maintenance requirements-are important for safe and satisfactory operation. The unit should be used for its intended application; alterations or modifications will void the Warranty.

WARNING:

As a routine laboratory precaution, always wear safety glasses when working with this apparatus.

This product is not intended, nor can it be used, as a sterile or patient connected device. In addition, this apparatus is not designed for use in Class I, II, or III locations as defined by the National Electrical Code.

Unpacking and damage

Save all packing material if apparatus is received damaged. This merchandise was carefully packed and thoroughly inspected before leaving our factory. Responsibility for its safe delivery was assumed by the carrier upon acceptance of the shipment; therefore, claims for loss or damage sustained in transit must be made upon the carrier by the recipient as follows:

Visible Loss or Damage: Note any external evidence of loss or damage on the freight bill, or express receipt, and have it signed by the carrier's agent. Failure to adequately describe such external evidence of loss or damage may result in the carrier's refusing to honor your damage claim. The form required to file such a claim will be supplied by the carrier.

Concealed Loss or Damage: Concealed loss or damage means loss or damage which does not become apparent until the merchandise has been unpacked and inspected. Should either occur, make a written request for inspection by the carrier's agent within 15 days of the delivery date; then file a claim with the carrier since the damage is the carrier's responsibility.

By following these instructions carefully, we guarantee our full support of your claim to be compensated for loss from concealed damage.

DO NOT --FOR ANY REASON --RETURN THIS UNIT WITHOUT FIRST OBTAINING AUTHORIZATION. In any correspondence to PRECISION SCIENTIFIC please supply the nameplate data, including catalog number and serial number.

General Information

These instructions encompass the model listed below.

<u>Cat. No.</u>	<u>Description</u>
73510	Universal Penetrometer

The Precision Universal Penetrometer is used to determine the consistency of semi-solid, solid materials. Since the universal model accepts all needles and cones, the flexibility is complete. In addition to petroleum tests, this unit has many applications in other industries.

This apparatus can also be used in the baking industry and other related fields. Cakes and breads have been tested with this apparatus by measuring the penetration, to determine their degree of softness. Binding powers of dried milk have also been found for the Penetrometer with materials other than petroleum products. While there may be no specific test or method, various manufacturers have established arbitrary standards, selecting one of the many cones offered. By maintaining set sample size, temperature, penetrating weight and time, a very workable test procedure may be established.

This penetrometer conforms to the following ASTM and ASA specifications: ASTM D-5, D-217, D-937, ASA Method 214.01 of Federal Test Specification SS-R-406C, and ASTM 211.3 of ASA Method of Federal Test Method 791, IP: 49, 50, 179; DIN: 51804, 51580.

ASTM Methods can be obtained from:

American Society for Testing Materials
1916 Race Street
Philadelphia, Pennsylvania 19103

Operation

Add the necessary weights to the plunger rod. In adding the weights to the plunger rod to make up the required load for the test, note that the weight of the standard test rod supplied is 47.5 grams. When the specified load for grease penetrations involving the use of a grease cone is 150 grams, no weights need to be added to the plunger rod if cone no. 73526 is used.

NOTE:

Be sure to use the two leveling screws and bubble level to level penetrometer before each use.

The combined weight of the cone (102.5 grams) and the test rod (47.5 grams) makes up the required load as specified by ASTM. Place the prepared sample in position on the base. Adjust the height of the mechanism head so that the point of the penetrating instrument is brought exactly into contact with the surface of the sample. This adjustment may be accomplished more easily by placing a weak light to one side of the sample container and following the shadow formed by the cone's tip on the surface of the sample until no light appears from its point.

To adjust the height of the mechanism head, release the lock screw. Make a coarse adjustment by means of the coarse adjusting screw (knob directly opposite the lock screw on the mechanism head).

NOTE:

Be sure to securely lock the head by means of the lock screw.

Make the final "contact" adjustment by means of the vertical micro-adjustable screw. Release the test rod, allowing the penetrating instrument to descend into the sample. To release the test rod, depress the thumb release lever. Hold it in its released position during the specified time required for the test.

OPERATION (Contd.)

A stopwatch should be used for noting the time. We recommend the Precision Time-It (Cat. No. 69240) that is solid-state with an easy to see LED readout. The Time-It is a table top timer; and with the accessory foot switch (Cat. No. 69242), one can keep both hands free for the operation of the penetrometer.

CAUTION:

In operating the thumb release lever, grasp the finger grip firmly with the forefinger. With the thumb, quickly depress the thumb release lever as far down as it will go. HOLD THE THUMB RELEASE LEVER DURING THE SPECIFIED TIME OF THE TEST. At the end of this time, release it quickly, allowing it to lock the test rod instantly.

NOTE

Before releasing thumb release lever, be sure that the dial pointer is set at zero. If it is not, adjust the "zero adjust nut" (Item 38) until dial pointer is pointing to zero.

Reading Penetration: To read the depth of penetration, push down the depth gauge rod gently, as far as it will go. The dial reading now indicates the depth of penetration directly in tenths of millimeters. For example: If the pointer comes to rest at the fourth mark past the 270 point, the depth of penetration is 274 tenth-millimeters, or 27.4 millimeters.

With the Precision Universal Penetrometer, penetration measurements can be made to a total depth of 62 mm on a single reading.

On depths greater than 38 mm, the dial pointer moves past the zero position for a portion of another revolution. Merely add the fractional revolution to determine the total depth of penetration.

Return the dial pointer to zero as directed in the preceding note. If the original zero setting has been accurate, the dial pointer will return exactly to zero and subsequent readings will check against standard gauge blocks.

Exclusive Precision® Warranty

PRECISION SCIENTIFIC warrants its products against defects in material or in workmanship, when used under appropriate conditions and in accordance with appropriate operating instructions for a period of no less than one (1) year from the date of delivery of the products.

Sole obligation of PRECISION SCIENTIFIC shall be to repair or replace at our option, FOB factory or locally, without charge, any part(s) that prove defective within the warranty period, provided the customer notifies PRECISION SCIENTIFIC promptly and in writing of any such defect. Compensation for labor by other than PRECISION SCIENTIFIC employees will not be our obligation. Part(s) replacement does not constitute an extension of the original warranty period.

PRECISION SCIENTIFIC MAKES NO WARRANTY OF MERCHANTABILITY, FITNESS FOR A PARTICULAR PURPOSE, OR ANY OTHER WARRANTY, EXPRESSED OR IMPLIED, AS TO THE DESIGN, SALE, INSTALLATION, OR USE OF ITS PRODUCTS, AND SHALL NOT BE LIABLE FOR CONSEQUENTIAL DAMAGES RESULTING FROM THE USE OF ITS PRODUCTS.

PRECISION SCIENTIFIC will not assume responsibility for unauthorized repairs or failure as a result of unauthorized product modifications, or for repairs, replacements, or modifications negligently or otherwise improperly made or performed by persons other than PRECISION SCIENTIFIC employees or authorized representatives.

While our personnel are available to advise customers concerning general applications of all manufactured products, oral representations are not warranties with respect to particular applications and should not be relied upon if inconsistent with product specifications or the terms stated herein.

In any event, the terms and conditions contained in PRECISION SCIENTIFIC formal sales contracts shall be controlling; and any changes must be in writing and signed by an authorized executive of PRECISION SCIENTIFIC.

All defective components will be replaced without charge one (1) year from the date of delivery. There will be no charge for labor if the apparatus is returned to the factory prepaid.

Conditions and qualifications of the warranty statement shall prevail at all times.

Precision® is a registered trademark of Precision Scientific Inc.

Parts List

	<u>Description</u>	<u>Qty.</u>	<u>Part No.</u>
1.	Plunger Rod Asssembly	1	521419
2.	Collar	2	521389
3.	Collet (chuck)	1	521390
4.	Rod, Plunger (only)	1	521414
5.	Bearing, Test Rod	2	521415
6.	Lock Screw Assembly	1	505759
7.	Cap Assembly	1	536227
8.	Groove-Pin (3/32 x 1/2)*	1	214109
9.	Pivot, Clutch	2	521405
10.	Jaws, Inner	2	521406
11.	Release, Clutch (test rod)	1	521407
12.	Spring, Clutch	1	521408
13.	Retainer, Clutch and Spring*	1	521409
14.	Lever, Clutch	1	533724
15.	Cap	1	536229
16.	Dial Hsg. Assy.	1	539079
17.	Retainer, Micro-Adj. Screw*	1	521380
18.	Adj. Screw Assy.	1	521421
19.	Housing, Micro Adj.	1	536235
20.	Cap, Micro Adj. Housing	1	536866
21.	Housing, Dial	1	539078
22.	Pin, Keyway (Dial Head Assy.)*	1	535810
23.	Dial	1	315865
24.	Glass Dial, 4 7/16 Dia.	1	330141
25.	Rod, Depth Gauge	1	509995
26.	Handle, Depth Gauge	1	521326
27.	Stop, Gauge*	1	521363
28.	Screw, Level	2	520197
29.	Nut, Pinion	1	521393
30.	Pointer*	1	521397
31.	Shaft, Pinion*	1	521422
32.	Pointer, Dial	1	521423
33.	Rod, Support	1	527095
34.	Pinion, Gauge Rod	1	533775
35.	Stud, Support Arm*	1	539080
36.	Weight, 50 gr.	1	73547
37.	Weight, 100 gr.	1	73548
38.	Nut, Zero Adjust	1	432005
39.	Nut, Weights	1	432006
40.	Spring Plunger	1	449373

ACCESSORIES:Cat. No.

Solid State Time-It	69240
Needle, ASTM D-5, 2.5 grams	73520
Needle, Certified, NBS, 2.5 grams	73522
Container, petroleum, 16 oz.	73523
Needle, wax penetration, ASTM D-1321, 2.5 grams	73524
Cone, aluminum, 35 grams	73525
Cone, brass ASTM D-217 & D-937, 102. 5 grams	73526
Cone and plunger, 1/4 size, ASTM D-1403, 9.38 grams	73533
Cone, Universal, 102.5 grams	73539

* Not shown

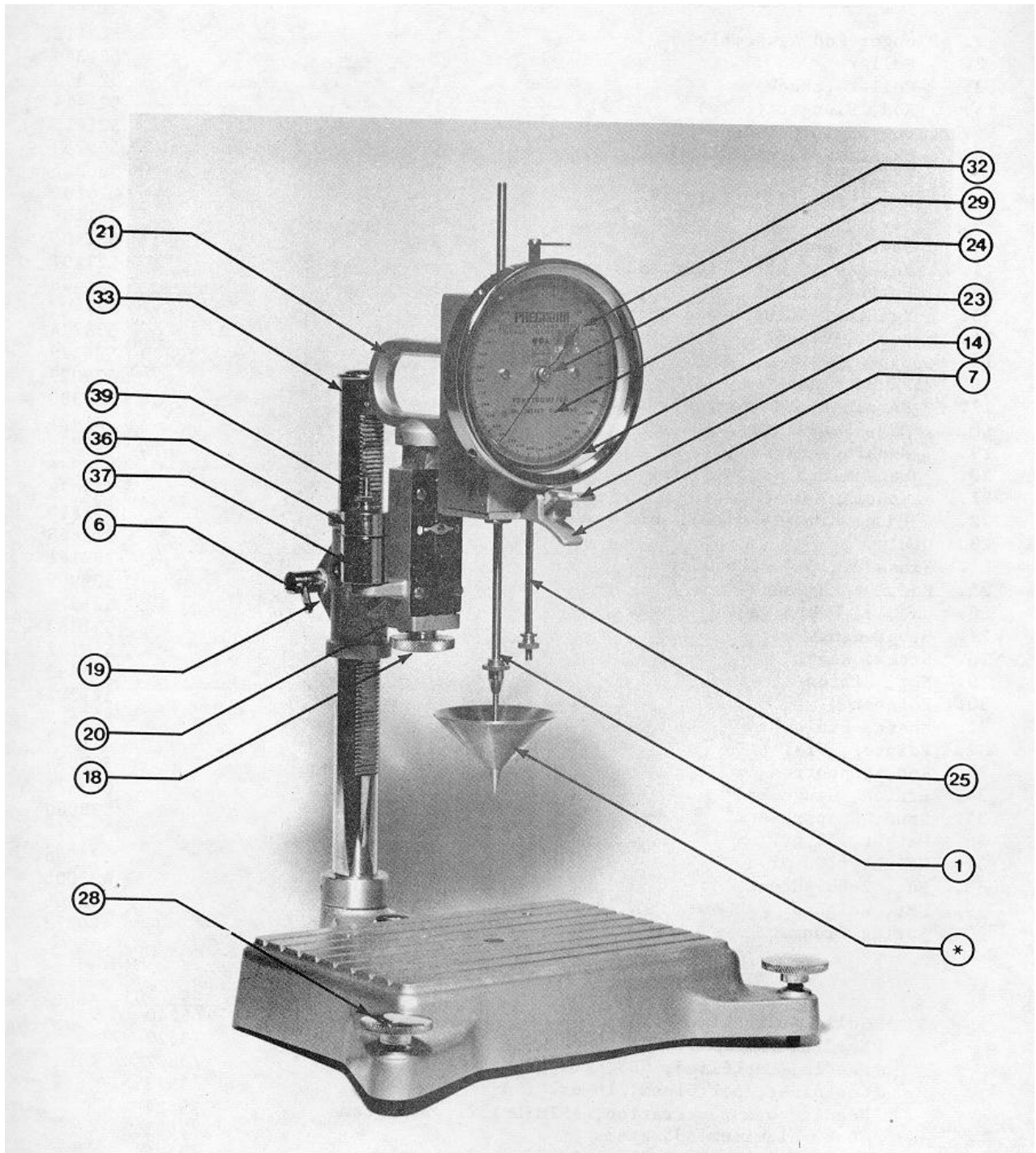

* cone not included, see accessories

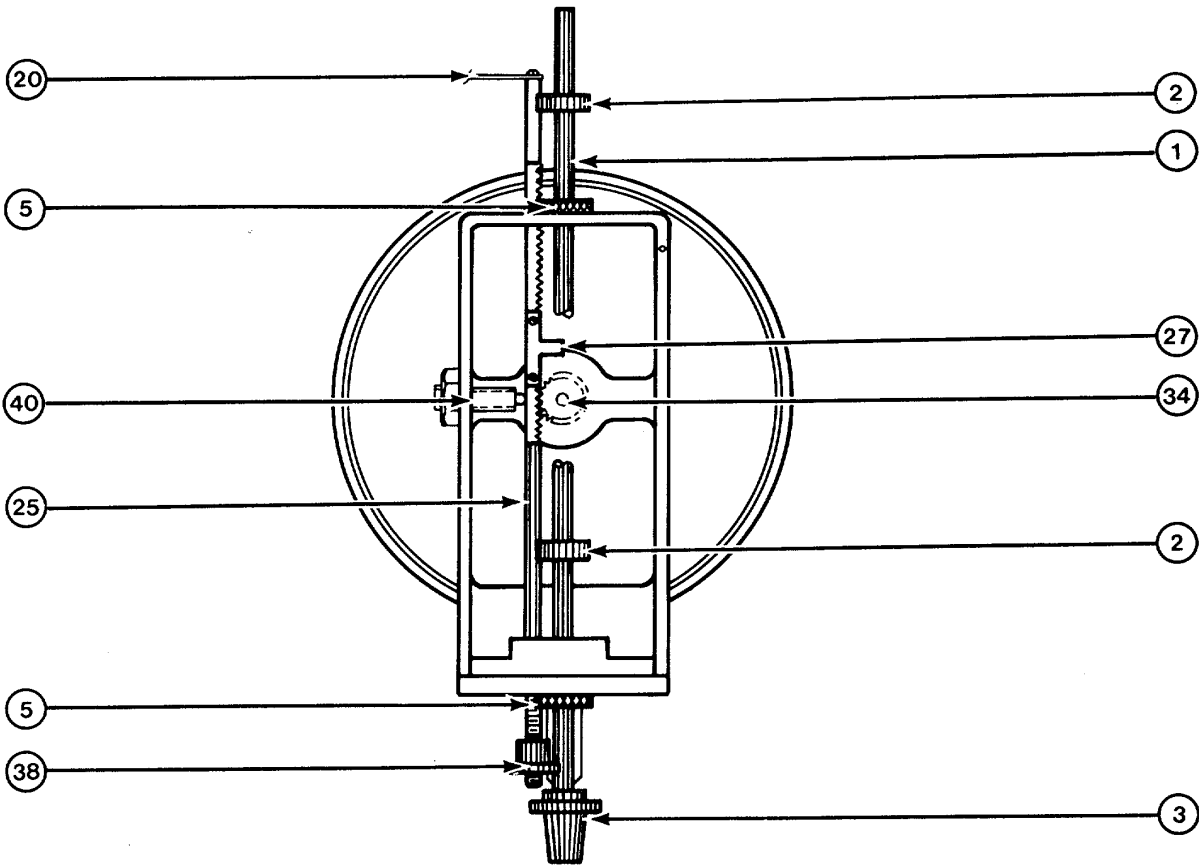

DIAL HOUSING ASSEMBLY
539079

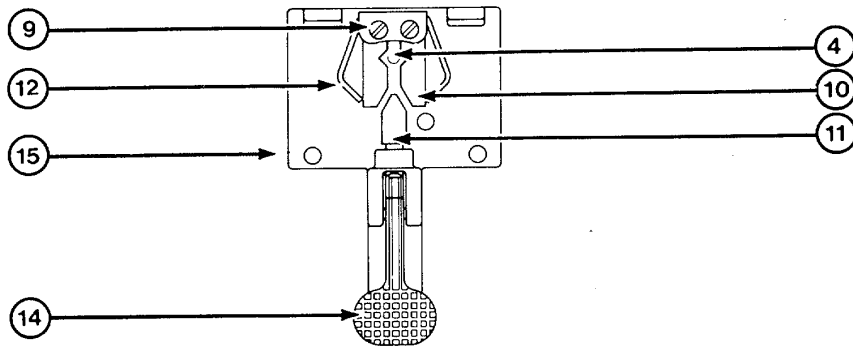

CAP ASSEMBLY
536227

APPENDIX A

REFERENCES

A-1. **Scope.** This appendix contains all forms, pamphlets and technical manuals referenced in both the Air mobile and Semitrailer mounted Laboratories.

A-2. **Forms.**

Recommended Changes to Publications	DA Form 2028
DA Form 2028-2	
Quality Deficiency Report	SF 368
Equipment Inspection and Maintenance Work Sheet	DA Form 2404
Hand Receipts	DA Form 2062

A-3. **Field Manuals.**

Petroleum Testing Facilities:

Laboratories and Kits	FM 10-72
Inspecting and Testing Petroleum Products	FM 10-70
ASTM Test Method Supplement to	FM 10-92C1/C2

A-4. **Technical Manuals.**

Atlas-Copco Compressor	TM 10-4310-392-13&P
Alcor Jet Fuel Thermal Oxidation Tester Operating and Maintenance Manual	TM 10-6635-210-13&P
Bacharach Gas Alarm and Calibration Data	TM 10-6665-297-13&P
Brother Portable Typewriter	TM 10-7430-218-13&P
Chemtrix Field Ph Meter	TM 10-6630-237-13&P
Elkay Manufacturing 30 GPH Cooler	TM 10-4130-240-13&P
Emcee Micro-Separometer	TM 10-6640-222-13&P
Foxboro Pressure Recording Gauge	TM 10-6685-365-13&P
Gammon Aqua Glo Water Detector	TM 10-6640-221-13&P
Gammon Mini Monitor Fuel Sampling Kit	TM 10-6630-230-13&P
Jelrus Burn-Out Furnace	TM 10-6640-231-13&P
Koehler Cleveland Open Tester	TM 10-6630-236-13&P
Koehler Cloud and Pour Point Chamber	TM 10-6630-238-13&P
Koehler Copper Strip Corrosion Bomb Bath	TM 10-6640-220-13&P
Koehler Distillation Apparatus	TM 10-6630-233-13&P
Koehler Dropping Point Apparatus	TM 10-6635-211-13&P
Koehler Electric Pensky-Martins Tester	TM 10-6630-231-13&P
Koehler Foaming Characteristics Determination Apparatus	TM 10-6640-228-13&P
Koehler Kinematic Viscosity Bath	TM 10-6630-239-13&P
Koehler Tag Closed Cup Flash Tester	TM 10-6630-235-13&P
Lab-Line Explosion Proof Refrigerator	TM 10-6640-219-13&P
Lily Freezer	TM 10-6640-234-13&P
Millipore OM 39 Filter Holder	TM 10-6640-225-13&P
Millipore Vacuum Pump	TM 10-6640-217-13&P
Ohaus Harvard Trip Balance	TM 10-6670-278-13&P
Precision Gas-Oil Distillation Test Equipment	TM 10-6630-219-13&P
Precision General Purpose Water Bath	TM 10-6640-229-13&P

Precision High Temperature Bronze Block Gum Bath	TM 10-6630-234-13&P
Precision General Purpose Ovens	TM 10-6640-218-13&P
Precision Heater Instruction Manual and Parts List	TM 10-6640-223-13&P
Precision Oxidation Stability Bath	TM 10-6640-232-13&P
Precision Pensky-Martens Flash Testers	TM 10-6630-231-13&P
Precision Reid Vapor Pressure Bath	TM 10-6640-226-13&P
Precision Slo-Speed Stirrer	TM 10-6640-224-13&P
Precision Universal Centrifuge	TM 10-6640-230-13&P
Precision Universal Penetrometer	TM 10-6640-228-13&P
Sargent-Welch Vacuum Pump	TM 10-4310-391-13&P
Sartorius Analytical Balance	TM 10-6670-277-13&P
Scotsman Cuber	TM 10-6640-227-13&P
Soltec VOM-Multimeter	TM 10-6625-3127-13&P
Teel Self-Priming Centrifugal Pump	TM 10-6640-217-13&P
Teel Submersible Pump	TM 10-4320-320-13&P
Texas Instrument TI-503011 Calculator	TM 10-7420-210-13&P

A-5. Pamphlets.

The Army Maintenance Management System (TAMMS)	DA Pam 738-750
--	----------------

A-6. Miscellaneous Publications.

The Army Integrated Publishing and Printing Program	AR 25-30
Laboratory, Airmobile, Aviation Fuel	MIL-L-52733A(ME)
Apparatus, Instruments, Chemicals, Furniture, and Supplies for Industrial, Clinical, College and Government Laboratories	Fisher Scientific Laboratories Catalog
Petroleum-Petrochemical Testing Equipment	Precision Scientific Catalog

APPENDIX B

MAINTENANCE ALLOCATION CHART

Section I. INTRODUCTION

B-1. General.

a. This section provides a general explanation of all maintenance and repair functions authorized at various maintenance categories.

b. The Maintenance Allocation Chart (MAC) in Section II designates overall authority and responsibility for the performance of maintenance functions on the identified end item or component. The application of the maintenance functions to the end item or component will be consistent with the capacities and capabilities of the designated maintenance categories.

c. Section III lists the tools and test equipment (both special tools and common tool sets) required for each maintenance function as referenced from Section II.

d. Section IV contains supplemental instructions and explanatory notes for a particular maintenance function.

B-2. Maintenance Functions. Maintenance functions will be limited to and defined as follows:

a. Inspect. To determine the serviceability of an item by comparing its physical, mechanical, and/or electrical characteristics with established standards through examination (e.g., by sight, sound, or feel).

b. Test. To verify serviceability by measuring the mechanical, pneumatic, hydraulic, or electrical characteristics of an item and comparing those characteristics with prescribed standards.

c. Service. Operations required periodically to keep an item in proper operating condition, i.e., to clean (includes decontaminate, when required), to preserve, to drain, to paint, or to replenish fuel, lubricants, chemical fluids, or gases.

d. Adjust. To maintain or regulate, within prescribed limits, by bringing into proper or exact position, or by setting the operating characteristics to specified parameters.

e. Align. To adjust specified variable elements of an item to bring about optimum or desired performance.

f. Calibrate. To determine and cause corrections to be made or to be adjusted on instruments or test, measuring, and diagnostic equipments used in precision measurement. Consists of comparisons of two instruments, one of which is a certified standard of knob accuracy, to detect and adjust any discrepancy in the accuracy of the instrument being compared.

g. Remove/Install. To remove and install the same item when required to perform service or other maintenance functions. Install may be the act of emplacing, seating, or fixing into position a spare, repair part, or module (component or assembly) in a manner to allow the proper functioning of an equipment or system.

h. Replace. To remove an unserviceable item and install a serviceable counterpart in its place. "Replace" is authorized by the MAC and is shown as the third position code of the SMR code.

i. Repair. The application of maintenance services,¹ including fault location/troubleshooting,² removal/installation, and disassembly/assembly procedures,³ and maintenance actions⁴ to identify troubles and restore serviceability to an item by correcting specific damage, fault, malfunction, or failure in a part, subassembly, module (component or assembly), end item, or system.

j. Overhaul. That maintenance effort (service/action) prescribed to restore an item to a completely serviceable/operational condition as required by maintenance standards in appropriate technical publications (i.e., DMWR). Overhaul is normally the highest degree of maintenance performed by the Army. Overhaul does not normally return an item to like-new condition.

k. Rebuild. Consists of those services/actions necessary for the restoration of unserviceable equipment to a like-new condition in accordance with original manufacturing standards. Rebuild is the highest degree of materiel maintenance applied to Army equipment. The rebuild operation includes the act of returning to zero those age measurements (hours/miles, etc.) considered in classifying Army equipment/components.

B-3. Explanation Of Columns In The MAC, Section II.

a. Column 1. Group Number. Column 1 lists functional group code numbers, the purpose of which is to identify maintenance significant components, assemblies, subassemblies, and modules with the next higher assembly. End item group number shall be "00."

b. Column 2. Component/Assembly. Column 2 contains the names of components, assemblies, subassemblies, and modules for which maintenance is authorized.

c. Column 3. Maintenance Function. Column 3 lists the functions to be performed on the item listed in column 2. (For a detailed explanation of these functions, see paragraph B-2.)

d. Column 4. Maintenance Category. Column 4 specifies, by the listing of a work time figure in the appropriate subcolumn(s), the category of maintenance authorized to perform the function listed in column 3. This figure represents the active time required to perform that maintenance function at the indicated category of maintenance. If the number or complexity of the tasks within the listed maintenance function vary at different maintenance categories, appropriate work time figures will be shown for each category. The work time figure represents the average time required to restore an item (assembly, subassembly, component, module, end item, or system) to a serviceable condition under typical field operating conditions. This time includes preparation time (including any necessary disassembly/ assembly time), troubleshooting/fault location time, and quality assurance/quality control time in addition to the time required to perform the specific tasks identified for the maintenance functions authorized in the maintenance allocation chart. The symbol designations for the various maintenance categories are as follows:

¹ Services inspect, test, service, adjust, align, calibrate, and/or replace.

² Fault locate troubleshoot-the process of investigating and detecting the cause of equipment malfunctioning; the act of isolating a fault within a system or unit under test (UUT).

³ Disassemble/assemble encompasses the step-by-steptaking apart (or breakdown) of a spare/functional group coded item to the level of its least componency identified as maintenance significant (i.e., assigned an SMR code) for the category of maintenance under consideration.

⁴ Actions welding, grinding, riveting, straightening, facing, remachining, and/or resurfacing.

- C Operator/Crew
- O Unit Maintenance
- F Direct Support Maintenance
- H General Support Maintenance
- D Depot Maintenance

e. Column 5. Tools and Equipment. Column 5 specifies, by code, those common tool sets (not individual tools) and special tools, TMDE, and support equipment required to perform the designated function.

f. Column 6. Remarks. This column shall, when applicable, contain a letter code, in alphabetic order, which shall be keyed to the remarks contained in section IV.

B-4. Explanation Of Columns In Tool And Test Equipment Requirements, Section III.

a. Column 1. Reference Code. The tool and test equipment reference code correlates with a code used in the MAC, section II, column 5.

b. Column 2. Maintenance Category. The lowest category of maintenance authorized to use the tool or test equipment.

c. Column 3. Nomenclature. Name or identification of the tool or test equipment.

d. Column 4. National Stock Number. The National stock number of the tool or test equipment.

e. Column 5. Tool Number. The manufacturer's part number.

B-5. Explanation Of Columns In Remarks, Section IV.

a. Column 1. Reference Code. The code recorded in column 6, Section II.

b. Column 2. Remarks. This column lists information pertinent to the maintenance function being performed as indicated in the MAC, section II.

Section II. MAINTENANCE ALLOCATION CHART

(1) GROUP NUMBER	(2) COMPONENT ASSEMBLY	(3) MAINTENANCE FUNCTION	(4) MAINTENANCE LEVEL				(5) TOOLS AND EQUIPMENT	(6) REMARKS	
			UNIT		DS	GS			DEPOT
			C	O	F	H			D
01	PENETROMETER	INSPECT REPLACE REPAIR	0.1	0.1 0.5				1	

**Section III. TOOL AND TEST EQUIPMENT REQUIREMENTS
FOR
MAINTENANCE ALLOCATION CHART**

(1) TOOL/TEST EQUIP. REF CODE	(2) MAINTENANCE CATEGORY	(3) NOMENCLATURE	(4) NSN	(5) TOOL NUMBER
1	O	TOOL KIT, GENERAL AUTOMOTIVE	5180-00-177-7033	(50890) SC 5180-90- CL-N26

Section IV. REMARKS

NOT APPLICABLE

APPENDIX C

COMPONENTS OF END ITEM AND BASIC ISSUE ITEMS LISTS

NOT APPLICABLE

C-1/(C-2 Blank)

APPENDIX D

ADDITIONAL AUTHORIZATION LIST

NOT APPLICABLE

D-1/(D-2 Blank)

APPENDIX E

EXPENDABLE/DURABLE SUPPLIES AND MATERIALS LIST

NOT APPLICABLE

E-1/(E-2 Blank)

By Order of the Secretary of the Army:

CARL E. VUONO
General, United States Army
Chief of Staff

Official:

THOMAS F. SIKORA
Brigadier General, United States Army
The Adjutant General

DISTRIBUTION:

To be distributed in accordance with DA Form 12-21A, Operator, Unit and Direct Support Maintenance requirements for Laboratory, Petroleum, MTD

* U.S. GOVERNMENT PRINTING OFFICE: 1990 654-126/20035

RECOMMENDED CHANGES TO EQUIPMENT TECHNICAL PUBLICATIONS

 <div style="border: 1px solid black; border-radius: 15px; padding: 5px; display: inline-block; margin-left: 20px;"> <p style="margin: 0;"><i>THEN...JOT DOWN THE DOPE ABOUT IT ON THIS FORM. CAREFULLY TEAR IT OUT, FOLD IT AND DROP IT IN THE MAIL.</i></p> </div>		SOMETHING WRONG WITH PUBLICATION		
		FROM: (PRINT YOUR UNIT'S COMPLETE ADDRESS)		
PUBLICATION NUMBER		DATE SENT		
PUBLICATION DATE		PUBLICATION TITLE		
BE EXACT PIN-POINT WHERE IT IS				
PAGE NO.	PARA- GRAPH	FIGURE NO.	TABLE NO.	<p style="text-align: center; font-weight: bold; margin-top: 0;">IN THIS SPACE, TELL WHAT IS WRONG AND WHAT SHOULD BE DONE ABOUT IT.</p>
PRINTED NAME, GRADE OR TITLE AND TELEPHONE NUMBER			SIGN HERE	

DA FORM 1 JUL 79 **2028-2**

PREVIOUS EDITIONS ARE OBSOLETE.

P.S.--IF YOUR OUTFIT WANTS TO KNOW ABOUT YOUR RECOMMENDATION MAKE A CARBON COPY OF THIS AND GIVE IT TO YOUR HEADQUARTERS.

The Metric System and Equivalents

Linear Measure

1 centimeter = 10 millimeters = .39 inch
 1 decimeter = 10 centimeters = 3.94 inches
 1 meter = 10 decimeters = 39.37 inches
 1 dekameter = 10 meters = 32.8 feet
 1 hectometer = 10 dekameters = 328.08 feet
 1 kilometer = 10 hectometers = 3,280.8 feet

Weights

1 centigram = 10 milligrams = .15 grain
 1 decigram = 10 centigrams = 1.54 grains
 1 gram = 10 decigram = .035 ounce
 1 decagram = 10 grams = .35 ounce
 1 hectogram = 10 decagrams = 3.52 ounces
 1 kilogram = 10 hectograms = 2.2 pounds
 1 quintal = 100 kilograms = 220.46 pounds
 1 metric ton = 10 quintals = 1.1 short tons

Liquid Measure

1 centiliter = 10 milliliters = .34 fl. ounce
 1 deciliter = 10 centiliters = 3.38 fl. ounces
 1 liter = 10 deciliters = 33.81 fl. ounces
 1 dekaliter = 10 liters = 2.64 gallons
 1 hectoliter = 10 dekaliters = 26.42 gallons
 1 kiloliter = 10 hectoliters = 264.18 gallons

Square Measure

1 sq. centimeter = 100 sq. millimeters = .155 sq. inch
 1 sq. decimeter = 100 sq. centimeters = 15.5 sq. inches
 1 sq. meter (centare) = 100 sq. decimeters = 10.76 sq. feet
 1 sq. dekameter (are) = 100 sq. meters = 1,076.4 sq. feet
 1 sq. hectometer (hectare) = 100 sq. dekameters = 2.47 acres
 1 sq. kilometer = 100 sq. hectometers = .386 sq. mile

Cubic Measure

1 cu. centimeter = 1000 cu. millimeters = .06 cu. inch
 1 cu. decimeter = 1000 cu. centimeters = 61.02 cu. inches
 1 cu. meter = 1000 cu. decimeters = 35.31 cu. feet

Approximate Conversion Factors

<i>To change</i>	<i>To</i>	<i>Multiply by</i>	<i>To change</i>	<i>To</i>	<i>Multiply by</i>
inches	centimeters	2.540	ounce-inches	Newton-meters	.007062
feet	meters	.305	centimeters	inches	.394
yards	meters	.914	meters	feet	3.280
miles	kilometers	1.609	meters	yards	1.094
square inches	square centimeters	6.451	kilometers	miles	.621
square feet	square meters	.093	square centimeters	square inches	.155
square yards	square meters	.836	square meters	square feet	10.764
square miles	square kilometers	2.590	square meters	square yards	1.196
acres	square hectometers	.405	square kilometers	square miles	.386
cubic feet	cubic meters	.028	square hectometers	acres	2.471
cubic yards	cubic meters	.765	cubic meters	cubic feet	35.315
fluid ounces	milliliters	29,573	cubic meters	cubic yards	1.308
pints	liters	.473	milliliters	fluid ounces	.034
quarts	liters	.946	liters	pints	2.113
gallons	liters	3.785	liters	quarts	1.057
ounces	grams	28.349	liters	gallons	.264
pounds	kilograms	.454	grams	ounces	.035
short tons	metric tons	.907	kilograms	pounds	2.205
pound-feet	Newton-meters	1.356	metric tons	short tons	1.102
pound-inches	Newton-meters	.11296			

Temperature (Exact)

°F	Fahrenheit temperature	5/9 (after subtracting 32)	Celsius temperature	°C
----	------------------------	----------------------------	---------------------	----

